

Captive Mounts// Type CM

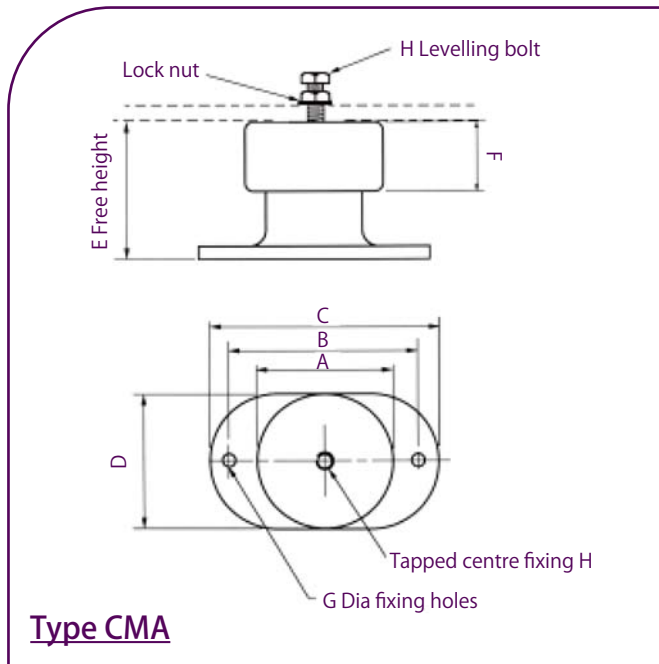

Type CMA

Type CM mounts are enclosed spring mounts, comprising of plated springs secured in a neoprene sealed housing. Type CMA has a zinc plated top cap and a neoprene bottom plate. Types CMB, CMC and CMD have a die cast alloy housing with an epoxy powder paint finish.

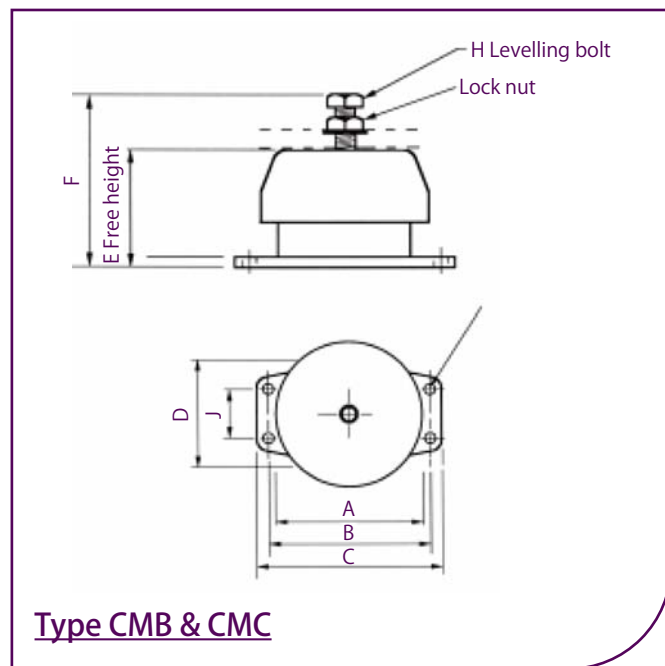
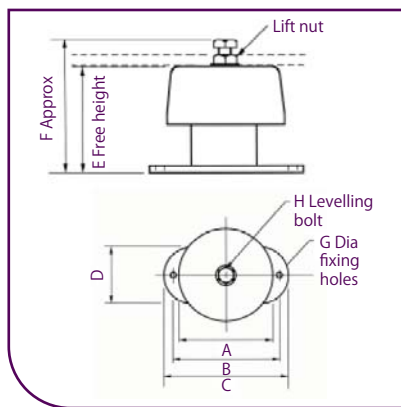

Type CMB & CMC

The top cap is separated from the bottom housing with neoprene snubbers. Caution should be taken to ensure the mounts are installed upright, with lateral forces minimised, so that contact between the top and bottom housings is not enough to degenerate the performance of the housed springs.

Dimensional Data mm									Load Range Kg	Nom Defl mm
Type	A	B	C	D	E	F	G	H		
CMA	64	83	102	64	-	59	31	10	7-210	15
CMB	99	110	130	62	-	102	165	11	11-364	25
CMC	124	148	173	73	-	130	190	14	34-864	25
CMD	196	210	242	141	65	165	235	20	340-2591	25