

## Open Spring Mounts// Type OM

Type OM are free standing, open coil mounts. The spring is positioned between a steel bottom load plate, bonded to a neoprene noise stop pad, and a steel top load plate.

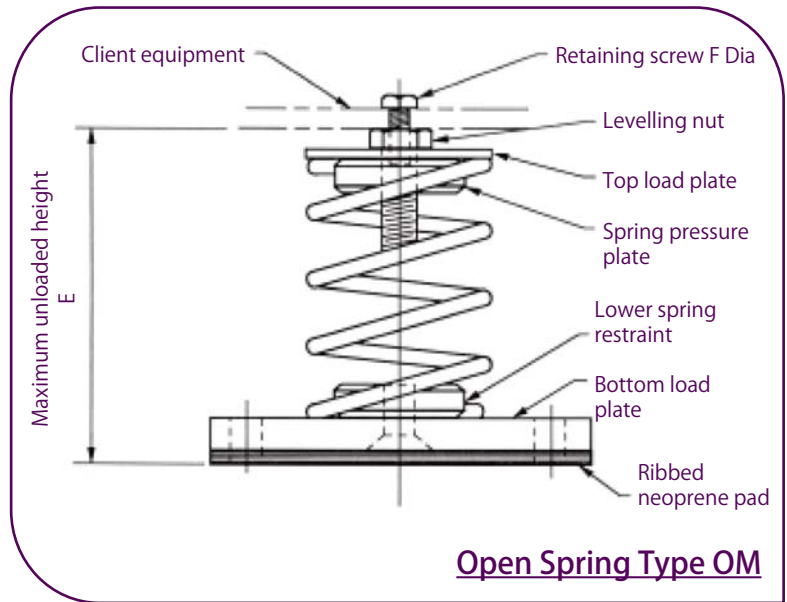

**Open Spring Type OM**

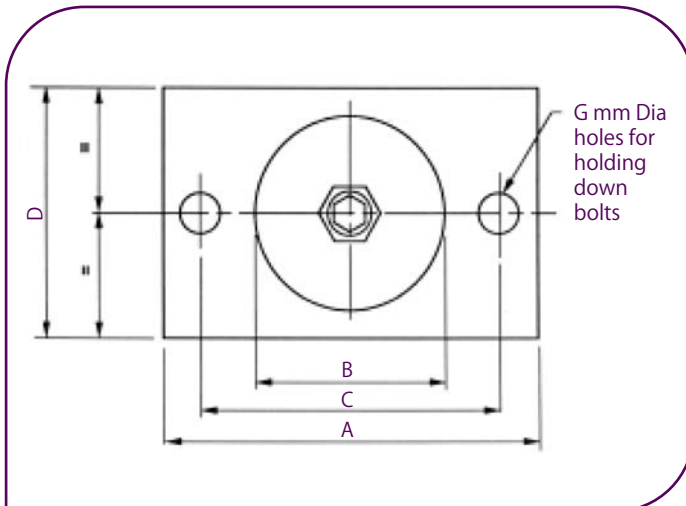

The spring is held in with two drilled and tapped steel restraints. The supported equipment is held between a levelling nut and retaining screw.

The mounts may be fixed down utilising the pre-drilled holes in the base plate.

Alternatively, the neoprene pad will act as a friction pad.

<i>Dimensional Data</i> mm								<i>Load Range</i> Kg	<i>Nom Defl</i> mm
Type	A	B	C	D	E	F	G		
OM/1A/25	120	70	92	80	130	10	14	11-500	25
OM/1/25	165	87	120	90	188	12	14	97-1091	25
OM/1/50	185	87	120	90	220	12	14	22-907	50
OM/1/75	170	105	142	130	245	12	14	22-907	75
OM/1/100	260	205	225	200	350	12	14	45-1361	100